

FUSO CANTER

FE83PE / FE83PG / FE85PG



**BOLD NEW FACE.
BETTER DRIVING
EXPERIENCE.**



EURO II

UNECE
REGULATION COMPLIANCE



3.9L 4D34 ENGINE

Built for the long run. Reliable performance comes hand in hand with power and fuel efficiency.

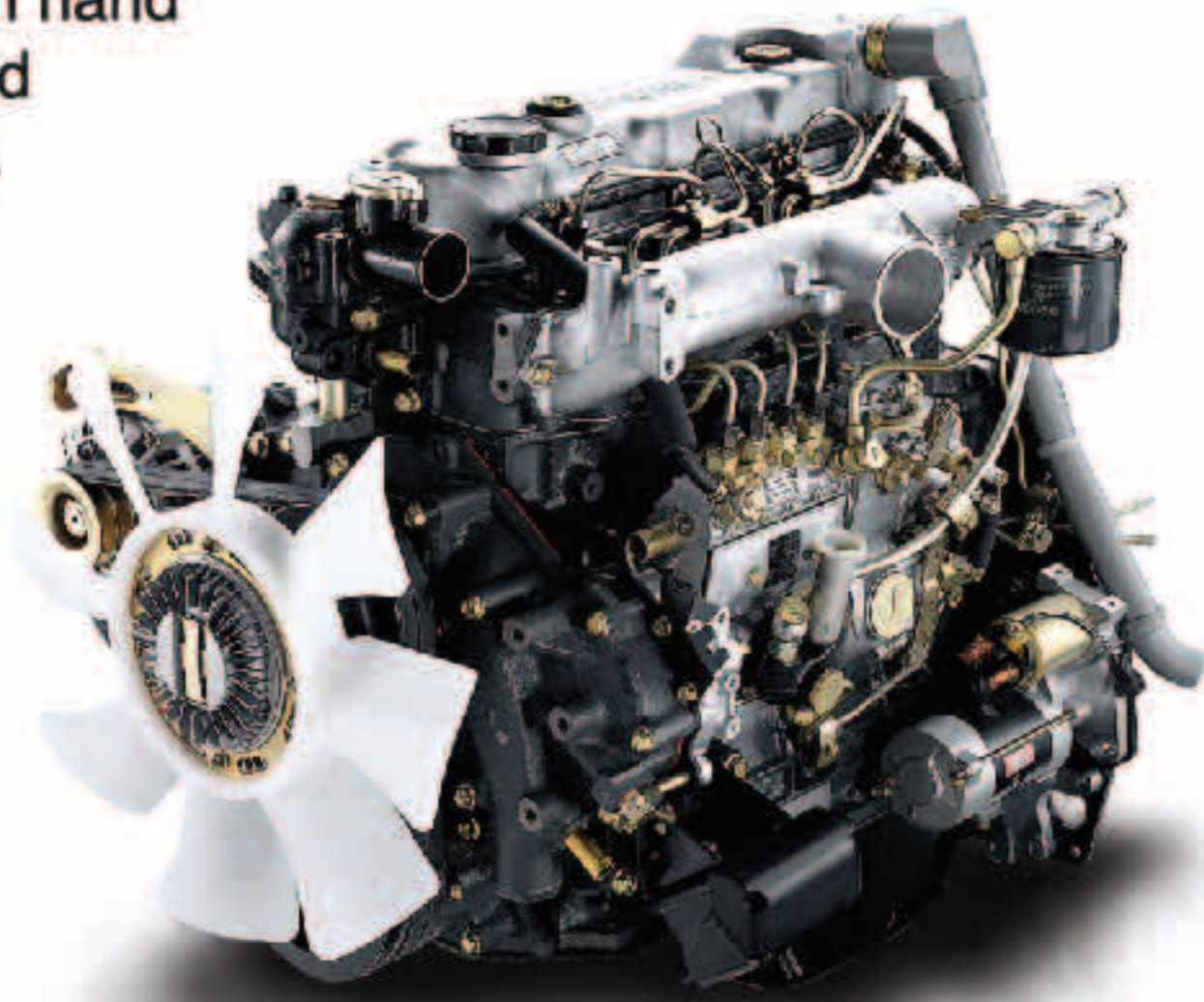

ANTI-LOCK BRAKING SYSTEM (ABS) and Automatic Brake Adjustor

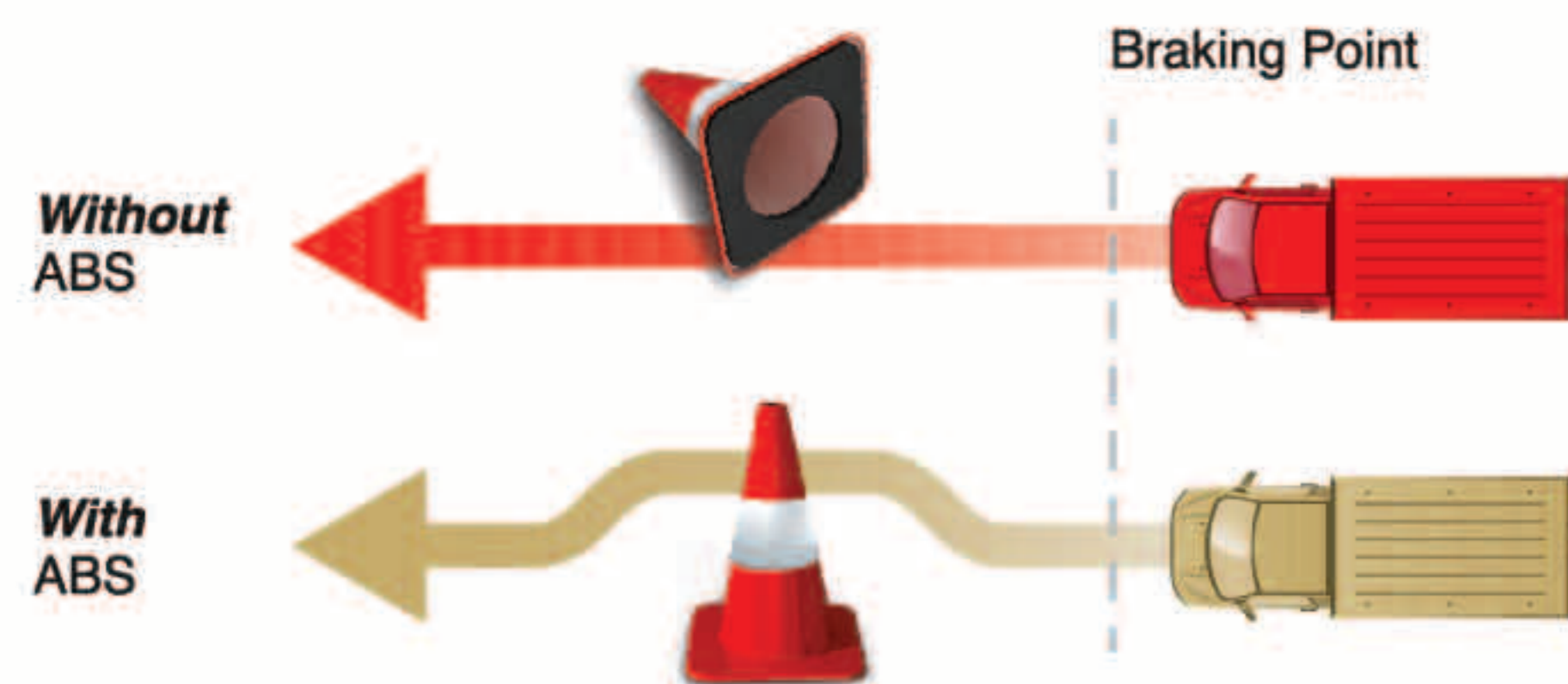

ABS help to maintain control of the vehicle during emergency braking situations, and enable proper steering around obstacles.

IN DASH GEARSHIFT



Easier operation and comfortable driving position. Provides ample leg room for easy shift from driver-seat to assistant-seat.



INTERIOR



01 New seat design with wide seat adjustment to provide comfortable driving position.



02 Simple, compact & functional dashboard. Ergonomic arrangement of switchers, levers and open storage space.



03 New stylish and easy-to-read instrument cluster.



04 Impact absorption steering column.



05 Central locking and power window.

EXTERIOR



06 Side marker lamp.



07 Headlamp levelling provide optimum headlamp and light projection distance. Comes with day time running lamp.



08 Reverse sensor for easy reverse operation.



09 6mm chassis frame.



10 Tubeless tyre providing longer tread life and gentle deflation in case of puncture.

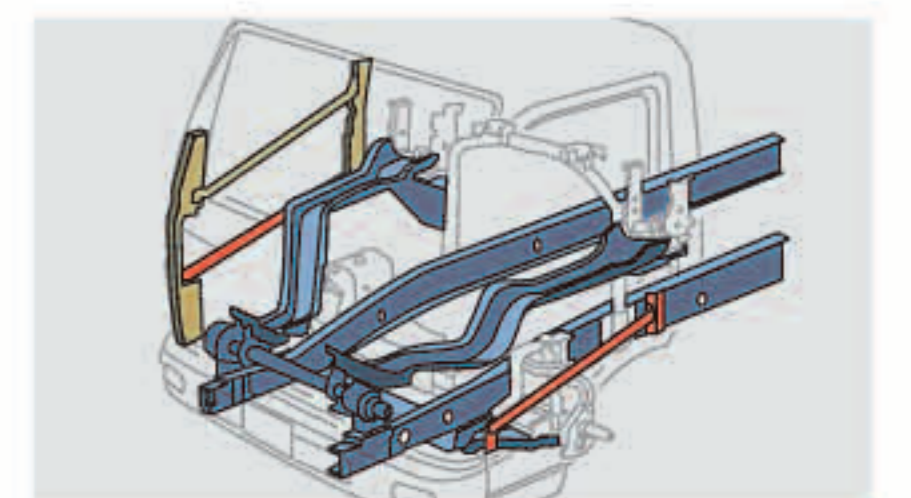

11 Fuso RISE Body with door impact beam, front box structure and reinforced cab floor main sill.

TECHNICAL SPECIFICATION



MODEL R.H.D		FE83PE6SRDG3 – 7.5	FE83PG6SRDG3 – 7.5	FE85PG6SRDG3	
WEIGHT	Max G.V.W.	kg	7,500	7,500	
	Front axle	kg	1,615	1,640	
	Rear axle	kg	760	780	
	Kerb weight approx.	kg	2,375	2,420	
DIMENSIONS	Wheelbase (W.B.)	mm	3,350	3,850	
	Overall length (O.A.L.)	mm	6,015	6,735	
	Overall width (O.A.W.)	mm	2,035	2,035	
	Overall height (O.A.H.)	mm	2,195	2,195	
	Tread	Front (T.F.)	mm	1,665	1,665
		Rear (T.R.)	mm	1,560	1,560
	Ground clearance approx. (G.C.)	mm	195	195	
	Cab to rear axle (C.A.)	mm	2,825	3,325	
	Cab to end frame (C.E.)	mm	4,305	5,025	
	Frame width (F.W.)	mm	753	753	
	Front overhang (F.O.H.)	mm	1,145	1,145	
	Rear overhang (R.O.H.)	mm	1,480	1,700	
	ENGINE	Model	-	Mitsubishi 4D34-2AT4 turbocharge with intercooler	
		Type	-	4-stroke, water-cooled, direct injection diesel engine	
No. of cylinders		-	4 in line		
Piston displacement		cc	3,908		
Max. output		kW(PS)@rpm	100(136)@2,900		
Max. torque		Nm@rpm	370@1,600		
Air cleaner		-	Dry paper element type		
Alternator		Volt	24V - 50Amps		
DRIVELINE	Clutch	Type	Hydraulic control, single dry plate		
		mm	300		
	Transmission	-	M035S5		
		-	5 forward and 1 reverse speed, manual, overdrive 2nd to 5th range; Synchromesh gears 1st & Rev. range; Constantmesh gears		
	Gear ratios	-	5.38-3.028-1.700-1.00-0.722-Reverse 5.380		
	Final reduction gear	-	Single reduction, hypoid gear		
Ratio	-	6.166			
CABIN	Seating capacity	-	3		
	Cabin tilt	-	Mechanical		
	Power windows	-	Equipped		
	Central lock & alarm system	-	Equipped		
	Reverse sensors & buzzer	-	Equipped		
	Kangaroo bar	-	Equipped		
CHASSIS	Axle type/Rating	Front	Reverse elliot, "I" beam type		
		Rear	Full floating type		
	Tyres	Studs	6		
		Tyre Size	215/75R17.5		
	Steering	-	Right hand steering. Ball nut type with integral type hydraulic power booster. Telescopic and tilt steering column with steering lock		
	Suspension	Front	Laminated leaf springs with shock absorbers		
		Rear	Main and auxiliary laminated leaf springs with shock absorbers		
	Brake	Service	Hydraulic with vacuum servo assistance, dual circuit with antilock brake system (ABS) & auto brake shoes adjuster		
		Parking	Internal expanding type on propeller shaft		
		Auxiliary	Exhaust brake		
Fuel tank	-	100 liters			
Electrical system	-	12 Volt x 2, 65Ah at 20 hr. rate			

FUSO Financial

FUSO Financial – A Daimler Financial Services Brand. The financial services provided by Mercedes-Benz Services Malaysia Sdn Bhd are regulated by the provisions of the Financial Services Act 2013. Mercedes-Benz Services Malaysia's operations are not within the regulatory purview of Bank Negara Malaysia.

MITSUBISHI FUSO authorised dealer:

100,000km
OR
3 YEARS WARRANTY*
LIGHT DUTY TRUCK

CUSTOMER CARE
CENTRE
1-800-88-1133

MITSUBISHI FUSO authorised distributor:
Mercedes-Benz Malaysia Sdn Bhd (596096-H)
Wisma Mercedes-Benz, 16A Jalan BK 1/13,
Taman Perindustrian Bandar Kinrara,
47180 Puchong, Selangor Darul Ehsan.
Tel : +603-8074 1188 | Fax : +603-8074 1199
www.fuso.my

Note: The information in this catalogue is to be regarded as approximate. The illustration may contain non-standard accessories and extras. Actual specifications may differ from the catalogue. We reserve the right to change the design, technical features and scope of delivery.